

# VETTECETERA

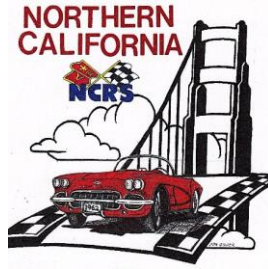

## Northern California Chapter's Newsletter for the Corvette Enthusiast

Vol. 41, Issue No.10

October, 2019

### 2019 NCC Officers

Chair	Sharyl Ingham	510 420-0968	<a href="mailto:sharylingham@gmail.com">sharylingham@gmail.com</a>
Vice Chair	Wayne Yurtin	408 888-5544	<a href="mailto:wayneyurtin@gmail.com">wayneyurtin@gmail.com</a>
Secretary	Sandy Houck	707 226-9108	<a href="mailto:sandyhouck@aol.com">sandyhouck@aol.com</a>
Treasurer	John Tidwell	530 432-2503	<a href="mailto:sampanjohn@earthlink.net">sampanjohn@earthlink.net</a>
Membership	Sharyl Ingham	510 420-0968	<a href="mailto:sharylingham@gmail.com">sharylingham@gmail.com</a>
Judging co-Chairs	Mike Ingham	510 420-0968	<a href="mailto:michael.ingham248@gmail.com">michael.ingham248@gmail.com</a>
	John Tidwell	530 432-2503	<a href="mailto:sampanjohn@earthlink.net">sampanjohn@earthlink.net</a>
Judging School Coordinator	Bob Grauer	925-922-2207	<a href="mailto:rob@inanutshell.com">rob@inanutshell.com</a>
Newsletter Editor	Marci Albers	707 448-4499	<a href="mailto:marcialbers@gmail.com">marcialbers@gmail.com</a>
CTFA Coordinator	Jeff Blakeslee	707 545-6393	<a href="mailto:JeffB@BlakesleeElectric.com">JeffB@BlakesleeElectric.com</a>
Webmaster	Chris Moore	415 939-6581	<a href="mailto:chrismoore@gmail.com">chrismoore@gmail.com</a>
NCRS President	Mike Ingham	510 420-0968	<a href="mailto:michael.ingham248@gmail.com">michael.ingham248@gmail.com</a>
Regional Director IX			
Librarian	Gary Beaupre	408 733-2845	<a href="mailto:garybeaupre@comcast.net">garybeaupre@comcast.net</a>
Refreshments Coordinator	Rick Gower	925-798-7877	<a href="mailto:gowerr@aol.com">gowerr@aol.com</a>

NCC/NCRS Website <http://www.ncrs.org/ncc/>

**Chapter Meeting Refreshments  
will be provided by  
Art & Glorie McNay**

### The Scoop

By Sharyl Ingham

Let me start with a short story about our first NCRS Judging experience. Mike and I joined the NCRS in 1999, and then joined NCC as well, right after we purchased our '62 FI. We signed up the car up for flight judging at the 2000 Regional meet at Harvey's in Lake Tahoe. Please note we were not only brand new to the organization but "GREEN to the Gills" to the judging system. We looked at this experience as an educational opportunity. OMG, what an eye-opener!

Again the long/short is that we got killed in Operations, but the beauty here was the judges. They made great notes of what was either missing or incorrect and 17 years later Mike achieved getting the Duntov award in San Antonio.

So where am I going with this, you ask? Nowadays when we get new members we encourage them to bring their cars to a Chapter meet to have them judged before going to a Regional. I am sure many of you follow this line of thinking, right? Well, we didn't do the Chapter meet first with the '69 but rather took it directly to the Lake Tahoe Regional for its initial judging. Oh no, Is history repeating itself? The big difference is that we knew how to prep the car for the judging journey. We knew there were some Operations areas where we'd get deductions but fortunately the other 4 areas deductions were minor thanks to the many "villagers" that helped

address our questions and potential issues. The achieved Top Flight Award is shared with y'all and believe me, you know who you are, thank you!

At the Lake Tahoe Regional we did a few things a bit differently, we offered "Challenge Coins" instead of having pins, which seemed to be a hit. Glorie McNay, with the help of Sandy Houck, Toni Koffman, and Bev LeGate, braved the cold weather on Thursday selling raffle tickets and then the raffle was held at the Welcome Reception that evening. What a great array of raffle items; thank you to those of you that donated items, and to those of you who bought raffle tickets. It seemed there was something for everyone! On Friday and Saturday morning before Judging started, Jeff Blakeslee brought his PA system and played the National Anthem. It just so happened there was a Flag attached to the Hard Rock Casino wall across the street where we were able to pay tribute. Joe Calcagno brought his cutaway C1 front suspension and conducted a seminar and people just wanted for Joe to talk and share more of his knowledge on Friday. Gary Bennett and Jim Rand conducted a 1-point judging school on the Mid-year Chassis on Saturday that was also appreciated by the attendees.

Although the Lake Tahoe Regional had a smaller than usual count of cars for judging, each and every one was magnificent. We had a surprise car, a '57 race car owned by '60s-era race driver Joe Frietas, that everyone enjoyed seeing as well as talking with Joe, it just doesn't get any better!

Awards Banquet Recipients from NCC, with the exception to Longest Driven and Longest Trailered, are as follows:

**Sportsman:**

- Jim Lockwood, 1960
- Kingston Wulff, 1963
- Wayne Yurtin, 1964
- Sandy Houck, 2002
- Mason McNay, 2014
- Jaime Gesundheit, 2016
- Bob Grauer, 2016
- Harry Inman, 2017
- Art McNay, 2017
- Jerry Palmer, 2019

**Duntov/Bowtie/Star Display**

- Rodger Schmidt, Duntov, 1961
- Mike McCracken, Bowtie/Star, 1966

**Performance Verification:**

- Dan Johnson, 1960
- Jeff Blakeslee/Bill Cash, 1963
- John LeGate, 2002

**Founders Operations Check:**

- Jerry Louer, 2001

**Longest Driven:**

- Mike Doty, 600 miles

**Longest Trailered:** we awarded the following six owners from Washington state; it was so fun and a surprise for them

- Joe Borelli, 1953
- Eric Falk, 1954,
- Doug Fearing, 1966
- Wayne Gibson, 1957
- Bob Johansen, 1967,
- Dan Johnson, 1960

**Top Flight**

- Bob Infantino, 1957
- Joe LeMay, 1957
- Frank and Laura Rodrigues, 1963
- Chris Springer, 1965
- Dana Richard, 1966
- Sharyl Ingham, 1969
- Ronald Doupe, 1971
- Michael Reichard, 1986
- Mark and Toni Koffman, 2002

**Ladies Choice:** saving the best for last.

- Sharyl Ingham, 1969

Think pink and wear pink the month of October for Breast Cancer Awareness. I am sure somewhere in your lifetime you know of someone that has had breast cancer/is a survivor, let's celebrate and honor them!

The October meeting is our nominating meeting. We have changed the date to the 15<sup>th</sup>, giving you an extra week to prepare for this very important meeting. If you have any doubts about being on the Board, please don't fret because I am very proud to say and I believe those that regularly attend can attest to a great working group. Remember if you don't attend your ears may be burning...

Every month I try to cite a National Day for something that may be of interest: National Homemade Cookies Day, (hint Melissa), October 1<sup>st</sup>; National Coffee with a Cop Day, October 2<sup>nd</sup>; National Dessert Day (as if we

need an excuse to eat dessert), October 14<sup>th</sup>; National Sweetest Day, October 19<sup>th</sup>; National Make a Dog's Day (this one cracked me up, can you see me making Willow's day any better?), October 22<sup>nd</sup>; and here is one for you Chocolate lovers, National Chocolate Day, October, 28<sup>th</sup>.

Please join with me in extending the following members birthday and anniversary best wishes: Jim Lockwood and Connie McGue sharing October 1<sup>st</sup>; Vince Anicetti, October 8<sup>th</sup>; Ray Muscat, October 9<sup>th</sup>; the Ingham's anniversary, October 10<sup>th</sup>; Jeff Howard, October 11<sup>th</sup>; Bob Kennard, Donna Hunter, and Bob Zimmerman sharing October 12<sup>th</sup>; Jerry Louer, October 13<sup>th</sup>; Dale Miller, October 14<sup>th</sup>; Alex Aivaliklis, October 15<sup>th</sup>; Rene Aivaliklis, October 16<sup>th</sup>; Don Hooper, October 17<sup>th</sup>; Michelle Carlton, October 18<sup>th</sup>; and Gary Beaupre, October 28<sup>th</sup>.

One item for your honey-do list: please check and update your profile!

Thank you for your time.

See you soon!





## **NCC Meeting Minutes: September 10, 2019**

Chairman Sharyl Ingham called the meeting to order at 7:00 pm and welcomed everyone back from a two-month no meeting break to the September meeting at St. Peter's Episcopal Church in Oakland. As usual, she asked the attendees to introduce themselves; stating their name, the city where they live, and the year(s) of their Corvette(s). The question of the evening was: Have you gotten your flu shot yet? With the exception of one member, everyone replied that they intend to next month.

The minutes of the June meeting were approved by the NCC Board via e-mail as submitted by Sandy Houck.

### **Treasurer's Report: John Tidwell**

John reported that the sponsorship for the Lake Tahoe Regional has been very successful.

### **Membership: Sharyl Ingham**

Sharyl happily reported that NCC now has 119 members, including 6 members since June.

### **Editor: Marci Albers**

Sharyl mentioned that since Marci was out of town, she prepared the September Vettectera. And so if there were any complaints it was to be addressed to her and not Marci.

### **Webmaster: Chris Moore**

Chris reported that he plans to do more updates after the Lake Tahoe Regional. Many people continue to comment on how much they like the new look of NCC's website. Thank you Chris!

### **NCRS President and Region IX Director: Mike Ingham**

Mike summarized his Restorer article about future National Conventions being organized by an NCRS National Team. Sign up to volunteer in an area that you are comfortable working in because it is all about the volunteers that make the Conventions successful, a known fact. The next Convention will be in a beautiful facility at French Lick, Indiana. The closest airport is Louisville, Kentucky.

### **Chapter Top Flight Award (CTFA): Jeff Blakeslee**

Jeff reported that the Chapter is on schedule for the second quarter. He continues to request Technical Articles so that NCC will have some in reserve as needed.



### **Refreshments: Rick Gower**

Rick passed the sign up sheet mentioning he still needs a volunteer or volunteers to bring refreshments for the December meeting.

### **Old Business:**

Sharyl did a quick recap reminding the members that at the June meeting the updated NCC Bylaws were signed and are now posted on the website.

### **Road Tour to Canepa**

The actual tour with a very knowledgeable Canepa docent, along with a road tour led by Ken Albers, and lunch at Bruno's, was extremely well attended. Sharyl thanked Wayne Yurtin for organizing and Ken Albers for leading the road tour.

### **Lake Tahoe Regional: September 19 - 21**

Sharyl is enthusiastic for the upcoming Regional. She told everyone that she has seen the printed programs and they look great. Mike reported that the registrations include 25 cars for Flight Judging, 13 Sportsman, 6 Performance Verifications, 3 Displays including 2 Duntovs and 1 Bowtie/Star, and 1 Founders Operations Check.

Sharyl started a dialogue about how nice it would be to play the National Anthem at the Regional. She went on to say that it is played at major events and places that she and Mike have gone to as well. It seemed there was a concurrence to that especially when Jeff mentioned that the Corvette is America's Sports Car. Jeff checked with the hotel and had clearance to play the National Anthem at 8:30 am on Friday and Saturday, this will kick off the judging. Sharyl reminded the men if they are there to please remove their hats.

Also new this year, the raffle will be held at the Welcome Reception at 7:00 on Thursday. Thanks to all who gave Glorie items for the raffle.

### **New Business:**

#### **2020 Midengine orders**

Glorie announced that Hendricks Chevrolet Dealer in Shawnee, Kansas has up to 19 available orders left and she was given permission to offer them to NCC members.

### **Nominations/Elections**

Sharyl asked whether there should be a more formal nomination process. Attendees did not see a reason to change. The game plan is to have Nominations at the

October meeting, and as always Elections will be in November.

### **Calendar**

NCC's Spring Meet in Suisun City on April 18-19 has been added to the calendar.

Sharyl urged everyone to support and attend other Chapter meets in the Region if at all possible. For the most part we list CCC, SCC, AZ, Southern AZ, and Southern NV events on our calendar. Remember, we are all part of the same club.

### **Break**

Thank you to Mark Pellowski and Casey Noel for providing cookies and drinks. Raffle prizes were won by Jeff Blakeslee, Benton Russell, and Gary Beaupre.

### **Show and Tell:**

**Wayne Yurtin** brought a T3 headlamp because Mike was looking for one for Sharyl's '69. It was not correct for C3, but appeared to be for a C2.

**Chris Moore** is getting his early '63 roadster ready for a PV. He started noticing that the throw out bearing was noisy. This resulted in him pulling the transmission and replacing the clutch. He brought the old throw out bearing retainer that is aluminum and shows a worn groove. The replacement is much sturdier cast iron.

**Sandy Houck** brought the old door rear window channel from her '67 coupe. She compared it to a new replacement channel, noting the differences in the outer metal bead.

**Rick Gower** is fascinated with the history of the four Corvettes that raced at the 1960 LeMans 24-hour race. He showed nice prints of the cars in 1960. Let Rick tell you the history and where the cars are now.

### **Adjournment:**

The meeting adjourned at 8:00 pm.

Respectfully submitted,  
Sandy Houck, NCC Secretary

### **New NCC Members:**

Please join with me in welcoming NCC's new members:

Bob Griffith, Lodi, CA  
Dennis Hakim, Ventura, CA  
Anthony and Paulette Mitchell, St. Helena, CA  
Harry and Linda Sadlock, Hampton, NH

## Verse by the Side of the Road

LITTLE WILLIE  
MODERN SOUL  
BUSTED PAPA'S  
BRUSH AND BOWL  
NICE WORK WILLIE

*Burma-Shave*

1937

## This 'n That:

By Glorie McNay

Happy Fall everyone. As we prepare for colder weather know that creatures large and small are doing the same. I have seen my first ant foraging in my kitchen. No one wants bug spray in their kitchen, there is a safe solution.

Wipe counters with white vinegar and water in a 50/50 solution. While your at it wipe down cabinets with this solution. Most floors are also safe to wipe down but I would suggest testing in an out of the way space.

There has been a lot of news about vegetation killers lately. If you want to kill weeds and grass growing in cracks of sidewalks or driveways pour a little strait vinegar on them.

Coating a windshield with a solution of three parts vinegar to one part water will keep it frost free if the car is left outside.

Vinegar is another magic product. Safe to use around food, kids and pets. Think of it before you reach for harmful chemicals.

For those of you who attended the California chapters Regional at Lake Tahoe a huge THANK YOU! Your support of the raffle was remarkable. There was a super team in every area and many more volunteered to help.

We look forward to seeing you in Texas.

## Stay Grounded

By Gary Hiltunen

A common problem that many early Corvette owners, those with 6-volt cars, have dealt with for years could best be defined as unreliable starting. To be clear I'm not referring to timing, fuel or spark issues but what would be better described as weak cranking power. Those familiar with a 6-volt system know that unlike a 12-volt car you have a limited amount of battery power

to get your car started. If the motor hasn't fired after a few revolutions (5-6) you are getting very close to having a drained battery. Taking into account that Chevrolet made millions of 6-volt autos without having a problem, why would this be happening now?

The answer might be something we as Corvette owners are very familiar with, grounding!

The trail that led to this theory started simply enough. My restorer was doing some work on a '54 for a client. One of the problems he was trying to sort out was the aforementioned starting issue. After replacing the well-used battery and checking the spark plugs & wires, setting the timing, inspecting the fuel system and still not seeing any noticeable improvement in starting the next logical step was to examine the starter. This is when the grounding theory as the cause for the poor starting came to light.

After taking the starter apart and inspecting everything the only obvious area of concern were the brush leads. These are a smaller version of the braided copper ground straps found on C-1s. The brush leads were showing the effects of excessive electrical resistance, burned, discolored, and stiff, in technical terms they were fried. After consulting with a starter/generator rebuilder and asking him why this was happening he made this statement, "You understand that the starter case is the ground?". So how was this related to the unreliable starting? FYI, the lead is bolted directly to the inside of the starter case.

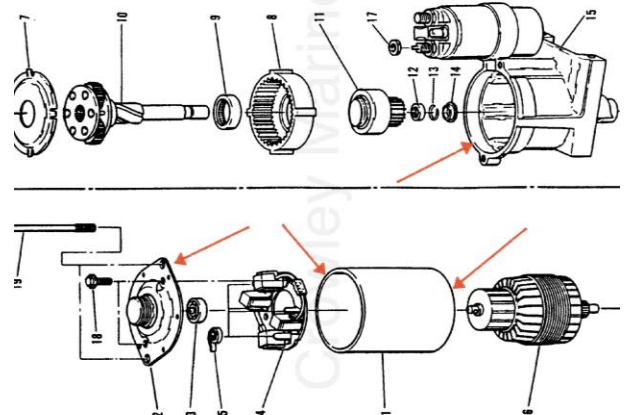

Because we were having the same starting issue with our '53, I decided we would go through it and fix any grounding issues we might find.

We began by removing the starter and checking it out. Sure enough, even though the starter had very light use since restoration, the leads also showed signs of resistance stress. Further investigation of the starter case showed that when it was restored the mating surfaces had been painted along with the outside. The rear mounting area of the starter was clean bare metal as you would expect.

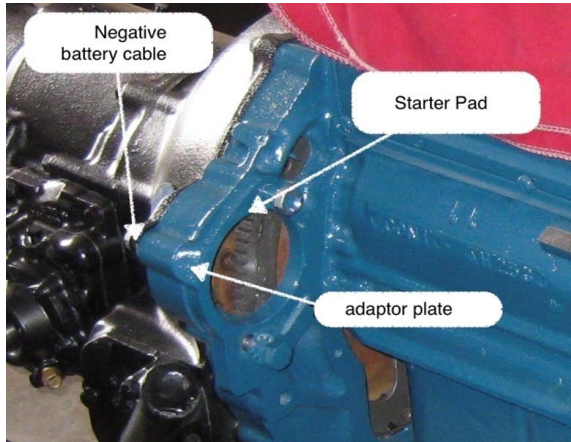

The starter is attached to an adaptor that mates the motor to the transmission. During our part of the restoration the entire adaptor was painted, including the starter mounting pad. The final grounding point is where the NEG. battery cable attaches to the transmission. This area was also completely painted when we restored the trans. Needless to say there were numerous areas from the NEG. cable to transmission, the adaptor starter pad and starter case to the brush leads, that obstructed a good ground.

After finding all this, the fix was relatively simple. We first replaced the brush leads with new HD ones and removed the paint from all mating surfaces on the starter case before reassembly.

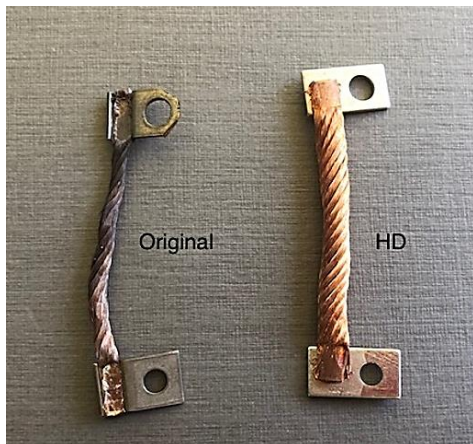

Moving on to the adaptor, the starter pad was cleaned down to bare metal removing all that beautiful Chevrolet Blue paint and the starter was bolted back in place.



Lastly, the NEG. cable attaching point on the transmission was also cleaned to bare metal before reattaching the cable.

After all this the question is, did it help?

In our case it did. Our '53 no longer has a starting issue and neither does the '54 that started this quest

**Rivet tool available for loan.**

If you are interested contact Mike Ingham at 510-420-0968 or [michael.ingham248@gmail.com](mailto:michael.ingham248@gmail.com)

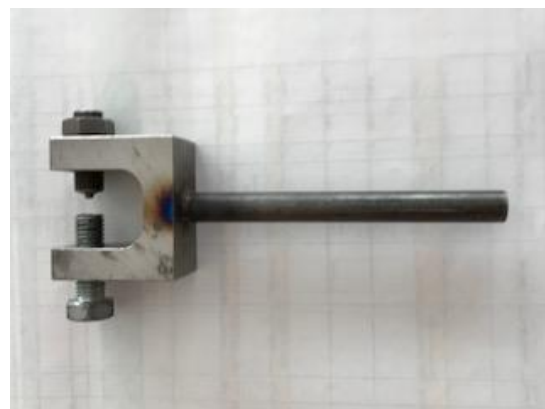

**Mass Mailing Clarification**

To make the Editor's job easier, I have asked Marci to start utilizing NCRS's Mass Mailing feature to distribute the Vettecetera as well as other NCRS related e-mails from other people. Please do NOT respond to her, respond to the person who authors the e-mail.

## Technical Articles Wanted

If you have been thinking about writing up some restoration project you have completed, please do so and submit it for publication. We can all benefit from one another's learning's. If possible, submit your article as a Word document, and any accompanying pictures as .jpg files.

## Copyrights

Articles appearing in the Vettecetera are the sole property of their author(s) and may not be reproduced without the express written permission of the author.

## Pertinent Information

Send newsletter articles to Marci Albers either by email: [marcialbers@gmail.com](mailto:marcialbers@gmail.com) or snail mail: 3949 Estate Drive, Vacaville, CA 95688. Either way it needs to be received **by the 25<sup>th</sup>** of the previous month to make publication.

## NCC Dues

NCC dues are \$30 per year. Please start paying via PayPal. If you choose to fill out a membership form it can be found on the last page of the Vettecetera. When and if you have changes (e.g., e-mail address, Corvettes owned) please send those changes to me via e-mail at: [sharylingham@gmail.com](mailto:sharylingham@gmail.com). Thank you.

## Chapter Meeting Location

The location for Chapter meetings is at St. Peter's Episcopal Church located at 6013 Lawton Avenue, Oakland, CA 94618.

## Note from editor:

In order to make things easier, all ads will be printed in the Vettecetera for 3 months. If you would like to run it longer just notify me, and I will run it for another 3 months. Also please notify me if you have sold your items, so I can delete your ad.

## Business Card Ads

Annual rates for business card ads are as follows: \$15 for NCC members; \$25 for non-NCC members. Please send your business card along with a check made out to NCC/NCRS to Marci Albers, 3949 Estate Drive, Vacaville, CA 95688.



**RARE**  
Raintree Automotive  
Restoration Enterprises  
*Joe Calcagno*  
P.O. Box 1080 • Soquel, CA 95073  
(831) 475 - 4442 PHONE  
(831) 475 - 1115 FAX  
[joe@rarecorvettes.com](mailto:joe@rarecorvettes.com)

**BLAKESLEE**  
ELECTRIC INC.  
INDUSTRIAL • COMMERCIAL  
LIC.# 416488

14 West Third Street  
P.O. Box 1951  
Santa Rosa, CA 95402

Tel (707) 545-6393  
Fax (707) 545-9617  
[JeffB@BlakesleeElectric.Com](mailto:JeffB@BlakesleeElectric.Com)



# FOLSOM CHEVROLET

"WHERE FRIENDS SEND THEIR FRIENDS TO BUY"  
12655 Auto Mall Circle • Folsom, CA 95630-8099



**MARSHAL CROSSAN**

Phone (916) 985-5600

Fax (916) 985-2515

marshal.crossan@folsomchevy.com

www.folsomchevy.com

**NCRS**  
NATIONAL CORVETTE RESTORERS SOCIETY  
The National Corvette Restorers Society  
Has created a new website  
**NCRS Classified ADS**  
The site is open to everyone, not just  
NCRS Members  
visit  
<https://www.ncrs.org>  
and click on "member services"  
to locate the  
NCRS Classified Ads  
link



- Spare tire locks
- NOS keys cut to code
- Key codes deciphered
- C2 correct bumper nuts & washers
- NOS Wheel Weights



Gary Beaupre 408-250-0370  
email: garybeaupre@comcast.net  
Website: www.garybeaupre.com



SAN FRANCISCO  
*Sports Cars*

BRAD GOLDSTONE  
PRESIDENT

191 INDUSTRIAL ROAD  
SAN CARLOS, CA 94070  
415.847.4169 CELL

650.585.2240 OFFICE  
BGOLDSTONE@SFSPORTSCARS.COM  
WWW.SANFRANCISCOSPORTSCARS.COM

## Alignment Shop

Honesty, Integrity, Quality

1819 N. Texas St., Ste. A  
Fairfield, CA 94533  
(Behind Food Max)

**707-399-7275**

Brakes, Suspension and more...

Owner  
Gary Steingass

## 2019-2020 Event Calendar

Date	Description	Location
<b>2019</b>		
October 8	NCC Meeting: Nominations for Officers	Oakland, CA
October 11-12	SCC Fall Meet	Temecula, CA
October 24-26	Texas Regional	Frisco, TX
November 3	Southern Las Vegas Chapter Fall Judging Meet	TBD
November 12	NCC Meeting: Elections for Officers and Book Drive	Oakland, CA
December 10	NCC Meeting	Oakland, CA
<b>2020</b>		
January 14	NCC Meeting	Oakland, CA
February 11	NCC Meeting	Oakland, CA
February 19-22	Florida Regional	Lakeland, FL
March 10	NCC Meeting	Oakland, CA
April 14	NCC Meeting	Oakland, CA
April 17-18	Northern California Spring Meet: Raffle	Suisun City, CA
May 12	NCC Meeting	Oakland, CA
May 14-16	Adirondack Regional	Latham, NY
May 28-30	Rocky Mountain Regional	Loveland, CO
June 9	NCC Meeting	Oakland, CA
June 11-13	North Central Regional	Rochester, MN
July 19-23	National Convention	French Lick, IN
August 20-22	Northwest Regional	Redmond, OR
September 8	NCC Meeting	Oakland, CA
October 13	NCC Meeting: Nominations for Officers	Oakland, CA
October 22-24	Texas Regional	Frisco, TX
November 10	NCC Meeting: Elections for Officers and Book Drive	Oakland, CA
December 8	NCC Meeting	Oakland, CA



# FALL Flight Judged Meet Registration Form

## FRIDAY & SATURDAY OCTOBER 11<sup>TH</sup> & 12<sup>TH</sup>, 2019

Holiday Inn Express 27660 Jefferson Avenue, Temecula, CA 92590

Event & Judging Questions Beverly & John LeGate Co-Judging Chairs 408-981-1200

Hotel: Holiday Inn Express, 27660 Jefferson Avenue, Temecula, CA 92590 951-699-2444

MENTION NCR BLOCK HELD UNTIL SEPTEMBER 11, 2019 \$165.00 King or Two Beds

**THIS IS A FIVE-POINT TWO-DAY JUDGED EVENT! REGISTRATION OPENS JULY 15, 2019.**

Cars must be in place by 8:00 AM Saturday, with a Judge's Meeting at 8:15 AM followed by an owners meeting.

We do request that you register ON-LINE or mail in the registration form on or before October 1, 2019.

**OPERATIONS CHECK FRIDAY October 11, 3 PM BY APPOINTMENT. FLIGHT & CONCOURS OWNERS WILL BE CONTACTED.**

Fees: Meet Registration Members \$20.00(spouse & children under 23 yrs.) \$25.00 Postmarked after Sept. 25, 2019 \$ \_\_\_\_\_

Meet registration Guests 1/2 of members' registration: \$10.00, Postmarked after Sept. 25, 2019, \$12.50 \$ \_\_\_\_\_

Flight Judging \$ 75 \$ \_\_\_\_\_

Sportsman Award \$13.00 (No Ribbon \$3) \$ \_\_\_\_\_

Concours Judging \$ 50 { } Stock { } Modified \$ \_\_\_\_\_

Join SCC/NCRS (Must be a NCRS National member) \$28.00 Link: <http://www.ncrs.org/scc/app.html> \$ \_\_\_\_\_

Or make checks payable to SCC/NCRS and Mail registration form and fees to: Beverly LeGate

PO Box 2739 Ramona, CA 92085 408.981.1200 [beverlylegate@yahoo.com](mailto:beverlylegate@yahoo.com)

Total \$ \_\_\_\_\_

The following information will be used on your judging summary sheet if you are having a car judged.

Please enter the following car for  Flight Judging 53-2002,  Sportsman Award,  Concours { } Previous Award display/Special interest Display (no fee). Please print legibly.

Year \_\_\_\_\_ Complete VIN # \_\_\_\_\_

**PRIORITY GIVEN TO FIRST TIME FLIGHT JUDGED OWNERS!!**

**Notice: There will be a limit of 10 Corvettes. First come first serve. No cars accepted after October 1, 2019 postmark.**

Horsepower \_\_\_\_\_ Exterior Color \_\_\_\_\_ Interior Color & Fabric \_\_\_\_\_

*Horsepower, Exterior Color, Trim Color and Fabric entries are mandatory for all vehicles. In addition, 1963 through 2002 vehicles must include all numbers and characters from the Trim Tag or Service Parts Identification Label with respect to Build Date, Paint Code, and Trim Code plus Body Number for 1963 through 1967 vehicles.*

Build Date \_\_\_\_\_ Paint Code \_\_\_\_\_ Trim Code \_\_\_\_\_ Body No. \_\_\_\_\_ Three Cars Per Division Limit

Convertible,  Coupe,  Corvette Driven,  Corvette Trailered,  Need trailer parking Miles Driven \_\_\_\_\_

I would like to help with:

Flight Judge,  Observer Judge,  Tabulate **JUDGING CERTIFICATE YES OR NO!** \_\_\_\_\_  Flight Judge,  Observer Judge,  Tabulate

Name \_\_\_\_\_ Name \_\_\_\_\_

Judging 1<sup>st</sup> Choice \_\_\_\_\_ 2<sup>nd</sup> Choice \_\_\_\_\_ Judging 1<sup>st</sup> Choice \_\_\_\_\_ 2<sup>nd</sup> Choice \_\_\_\_\_

Ops Interior Exterior Mech or Chassis (circle two) \_\_\_\_\_ Ops Interior Exterior Mech or Chassis (circle two) \_\_\_\_\_

Member, \_\_\_\_\_ Spouse \_\_\_\_\_

Guest \_\_\_\_\_ Address \_\_\_\_\_

City \_\_\_\_\_ State \_\_\_\_\_ Zip \_\_\_\_\_

E-mail: \_\_\_\_\_ Chapter Affiliation (if any): \_\_\_\_\_

Phone (Home): \_\_\_\_\_ Work: \_\_\_\_\_ Cell: \_\_\_\_\_

NCRS National Membership Number (see mailing label on your Driveline or Restorer): \_\_\_\_\_

**REGISTRATION OPENS FRIDAY AT 1PM. ALL ACTIVITIES WILL BE AT THE HOLIDAY INN EXPRESS.**

**JUDGING SCHOOL TBA FRIDAY 5-6PM # ATTENDING \_\_\_\_\_**

**FRIDAY NO HOST DINNER TBA 6:30PM # ATTENDING \_\_\_\_\_**

**SEE OUR FLYER ON OUR NCRS SOUTHERN CALIFORNIA WEBSITE FOR CURRENT TIMES & LOCATIONS.**

I AGREE to insure my vehicle and property against loss, damage and liability and to provide proof of such insurance to NCRS at time of registration...

I AGREE to assume risk of any and all damages or injury and to indemnify and hold harmless NCRS, it's officers, directors, agents, employees, chapters and meet workers for any acts or omissions which may result in the theft, damage or destruction of my property or injury to me or others occurring during, or as a consequence of this event, wherever located.

I AGREE to abide by the NCRS Policy on Drugs and Alcohol (revised 2005). The use of drugs or alcohol by anyone attending an NCRS event including NCRS members, family members, guests, and vendors is prohibited while participating in any judging meet, driving tests and/or road tours.

**Please fill in the required information below. You must also provide/bring proof of in-force liability insurance and current registration for the Corvette to be judged. PLEASE INCLUDE COPIES OF YOUR CURRENT INSURANCE AND REGISTRATION CARD IF MAILING FORMS.**

Company \_\_\_\_\_ Policy # \_\_\_\_\_ Expiration Date \_\_\_\_\_

Signature \_\_\_\_\_ Date \_\_\_\_\_



**SPONSOR COMMITMENT:**

We hope you will make a decision to be an Individual Sponsor, make a pledge or give a donation to the Lake Tahoe Regional. Trust me when I say this organization is full of Corvette enthusiasts.

Regional Meets are very costly and we don't often ask our own membership to make a donation, but this year is different. We are hoping that each chapter member becomes an individual sponsor with a minimum donation of \$25. We always seem to rely only on the major Sponsors but we, the members, should take some ownership as well. It is your club!

Just to give you an idea of the costs per day for the Judge's and Tabulator's meals, breakfasts and lunches (Friday and Saturday) are about \$2500. When Glorie solicits sponsors she is usually asking for a \$500 donation to help defray these costs. To her credit she does a smash up job by at least getting three sponsors per day.

What is your pleasure?

Name: \_\_\_\_\_

Address: \_\_\_\_\_

Telephone: \_\_\_\_\_

E-Mail: \_\_\_\_\_

If you have a business card please include it with your check so that we can include it in the Program booklet. Thank you.

Please make out your checks payable to NCC/NCRS and mail to:

Mr. John Tidwell, NCRS CFO  
P.O. Box 2080  
Penn Valley, CA 95946

**Northern California Chapter Membership Form**



SHARYL INGHAM at 6047 Lawton Avenue, Oakland, CA 94618

**ANNUAL DUES:** January 1st through December 31st, **\$30; now payable via PayPal through the NCRS website.**

Business Card Ad: \$15 for NCC member, \$25 non-NCC member

Please send a jpeg of your business card to: marcialbers@gmail.com

**NCRS Membership Number:** \_\_\_\_\_ Expiration

Date: \_\_\_\_\_

(From *Driveline* or *Restorer* Address Label)

You must be an NCRS Member to be a Chapter member

**Check as Applicable:**

\_\_\_\_\_ New Member

\_\_\_\_\_ Renewal

\_\_\_\_\_ Change of Address

**Please Print or Type**

Name \_\_\_\_\_ Birthdate: Month \_\_\_\_\_ Day \_\_\_\_\_

Spouse \_\_\_\_\_ Birthdate: Month \_\_\_\_\_ Day \_\_\_\_\_

Street \_\_\_\_\_ Apt. \_\_\_\_\_

City \_\_\_\_\_ State \_\_\_\_\_ ZIP \_\_\_\_\_

Home Phone \_\_\_\_\_

Cell Phone \_\_\_\_\_ (SEP)

Work Phone \_\_\_\_\_

E-mail \_\_\_\_\_

Please list the Year(s) and Model(s) of your Corvette(s)

\_\_\_\_\_  
\_\_\_\_\_  
\_\_\_\_\_

This information will be published in the Chapter's roster.

Please check your exclusions.

\_\_\_\_\_ Name

\_\_\_\_\_ Birthdate

\_\_\_\_\_ Street Address

\_\_\_\_\_ City (SEP)

\_\_\_\_\_ Phone

\_\_\_\_\_ NCRS#

\_\_\_\_\_ E-mail